

EPS-DUAL

ADVANTAGES:

1. More easy installation.
2. Positioning of the central unit directly on the inside surface of the bumper without the connecting cable between the ECU and antenna sensor in order to have a more reliable working capability of the system.
3. Possibility to chose more or less sensitivity with a simple connection of the proper wire to th earth.
4. Just the same electronic unit (ECU) that can be used indifferently on the front or on the back of the car with a simple connection of the proper wire to the earth (the front sensor has different sounds compared with the back).

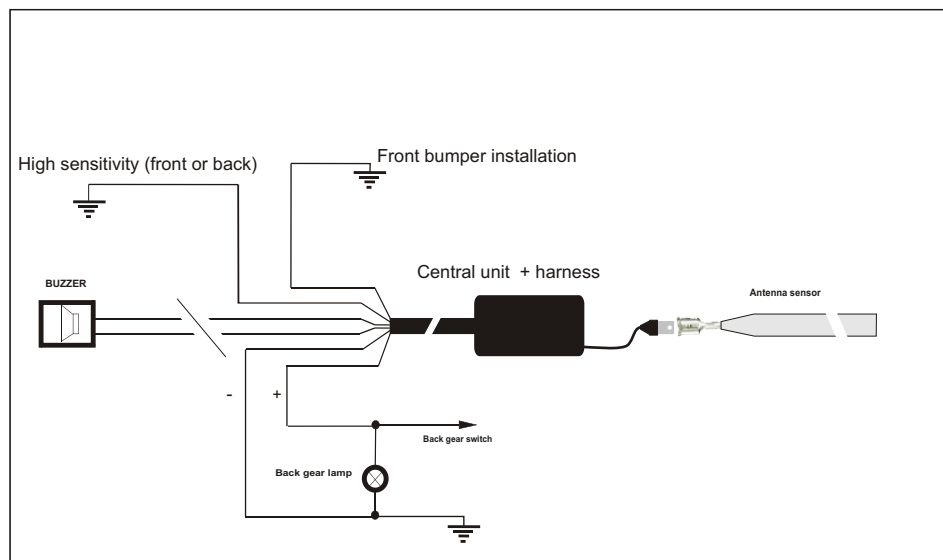
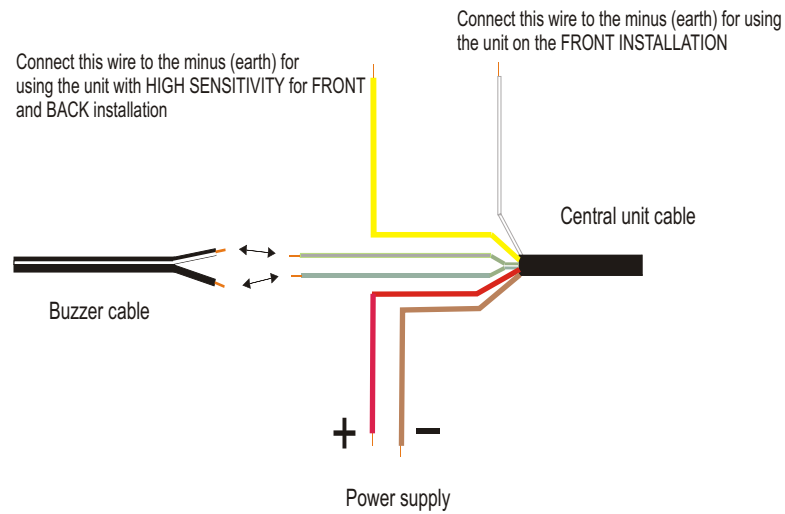

Block schematic